

Specifications

Output Power HP (kW)	3 (2.2)
Phase	3 Phase
Pole	6 Pole
Frame Number	112M

Degrees of Protection	IP 22
Enclosure Construction	Drip-proof
Thermal Class	Class B (130°C)

Alignment	Vertical
Frame Material	Steel plate

Power Transmission	Direct-couple or Belt Driven
Direction of Rotation	Counterclockwise (CCW) viewed from shaft-end side



Connection Type	Lead Wire (6 Leads)
Coating Colour	Munsell N5.5 (Gray)
Conformed Standard	IEC 60034-1 & JEC-2137-2000



Voltage & Frequency	LT Type	
	220/380~415V	50Hz
	220/440V	60Hz

* () is dimension without drip-proof cover

Dimensions (mm)

Flange Number	Motor								
	D	IE	LA	LB	LC	LE	LG	LL*	LZ
FF215	190	141.5	215	180 j6	250	4	16	352 (329)	14.5

Terminal Box			Shaft End						
KB	KD	KL	LR	Q	QK	S	T	U	W
263	27	166	60	60	45	28 j6	7	4	8

Bearing No.		Approximated Weight (kg)	Approximated Packing Dimensions (LxWxH)	Gross Weight (kg)
Drive End	Opposite			
6207ZZ	6206ZZ	41	390 x 387 x 354	45

Connection & Connection Diagram

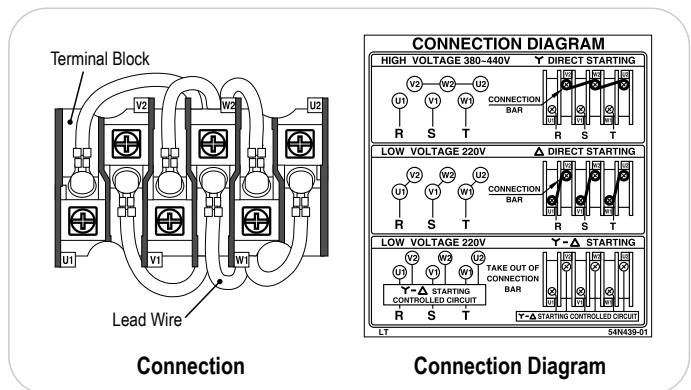

Circumstance Conditions

Ambient Temperature	-20 ~ +40°C
Ambient Humidity	85% RH or less
Operating Altitude	Less than 1,000m above sea level
Environment	No bursting / erosive gas or vapor

Motor Characteristics

Type	Hz	V	50% Load			75% Load			100% Load				Torque(%)		Is (A)	Inertia GD ² (kg-m ²)	
			(A)	Eff(%)	PF(%)	(A)	Eff(%)	PF(%)	(A)	Eff(%)	PF(%)	Speed (r/min)	Torque (kg-m)	Ts			Tm
LT	50	220	6.61	0.82	0.53	7.74	0.85	0.66	9.21	0.84	0.75	940	2.28	261	266	53.7	0.064
		380	3.82	0.82	0.53	4.47	0.85	0.66	5.32	0.84	0.75	940	2.28	261	266	31.0	
		415	4.14	0.82	0.45	4.63	0.84	0.59	5.29	0.85	0.68	950	2.26	313	315	33.7	
	60	220	5.65	0.85	0.60	6.98	0.85	0.73	8.64	0.85	0.79	1120	1.91	197	227	45.9	
		440	3.51	0.81	0.51	4.03	0.84	0.64	4.70	0.85	0.72	1140	1.88	266	303	30.5	